

PYC35A

Prime Power: 24KW/30KVA

Standby Power: 26KW/33KVA

Voltage: 400V

Powered by Yuchai YCDV254FHZ-40 Engine

Genset Performance

- 230/400V, 50Hz, 0.8PF, 3 Phases 4 wires
- Frequency drop $\leq 3\%$
- Voltage regulation $\leq 0.3\%$
- The steady state frequency $\leq 0.5\%$
- The steady state voltage deviation $\leq \pm 1\%$
- The transient frequency deviation $\leq +10\%$ $\leq -15\%$
- The transient voltage deviation $\leq +20\%$ $\leq -15\%$
- Frequency recovery time $\leq 3S$
- Voltage recovery time $\leq 1S(\text{Voltage} \pm 3\%)$
- THF (Telephone Harmonic Factor) < 3
- TIF (Telephone Influence Factor) < 50
Comply to Standard NEMA MG1-22.43
- Standard equipped with ambient temperature 40°C
Connecting radiator
- Built-in vibration isolator with high performance on
shock absorption.
- Product standards: (1) GB/T 2820-2022 / IS08528:2018
(2) GB/T 4712-2008 (3) YD/T 502-2020 (4) YD/T 1051-2018

Optional Items

- Starting batteries
- Fuel tank
- Oil-water separator
- Sensor for low coolant level, low fuel/oil level
- Automatically monitoring & controlling system of city power
- Coolant heater
- Oil heater
- Heat exchanger--Water cooled tower system
- Silent type/Trailer
- Standardized container
- Design and construction of environmental protection; engineering for the Genset room.

Standard Configuration

- Guangxi Yuchai Engine
- Brushless synchronous alternator
- POWERTEC intelligent controller
- 40°C standard ambient temperature
(50°C Optional)
- Circuit breaker (3P)
- Float battery charger
- Battery connect wire
- Steel base frame
- Silencer, bellows, exhaust bend
- Bottom fuel tank
- Manual book and files

Diesel Engine

- Model: YCDV254FHZ-40
- YCD4 series engines are key control subsidiaries of Guangxi Yuchai Machinery Group Co., Ltd. The model produced by Guangxi Yuchai Power Co., Ltd. is a small-bore multi-cylinder diesel engine produced by Yuchai Group. The production base of diesel engines has the annual production capacity of 300,000 units of multi-cylinder small-bore diesel engines;
- The engine has compact structure, small size, light weight and easy maintenance on one side;
- Tunnel-type linerless body has good rigidity and low oil consumption (the engine-fuel ratio is less than 0.1%);
- Electronically controlled fuel supply system, low swirl ratio air passage, multi-hole small-diameter injector, strong power, Excellent performance and good economy;
- NVH optimization, low noise and vibration, reaching the advanced level of similar international models;
- Can be relayed and remotely monitored, easy to operate; the machine filter and diesel filter are arranged on the same side, easy to maintain;
- Adopt internationally renowned brand fuel pump;

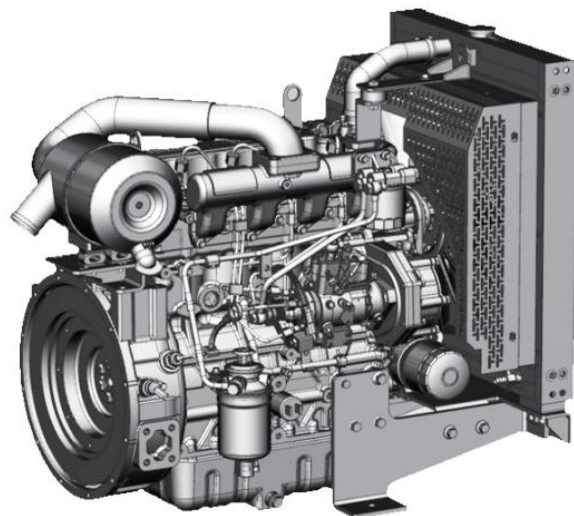

Alternator

- Optional brands: **Stamford / Marathon / Faraday / Engga / Mecc Alt**
- Brushless, 4 pole rotating magnetic field, single bearing with protective cover.
- Insulation: H Class.
- IP Class: IP23
- Cooling system
- AC exciter, rotate rectifying
- The stator winding is impregnated and the surface is covered with moisture-proof epoxy insulating paint.
- Rotor and exciter made with high temperature insulating resin, to satisfy tough environment.
- Rotor dynamic balancing complys for BS5625, class 2.5
- Sealed with advanced lubricating grease to prolong life of bearing.



Standard Meters

- 3 phases voltage: U_a, U_b, U_c
- Frequency F_1
- Apparent power PR
- Power factor PF
- Coolant temperature WT
- Temperature $^{\circ}C$ display
- Oil pressure OP
- Engine speed
- 3 phases current: I_a, I_b, I_c
- Active power PA
- Power factor PF
- Temperature $^{\circ}C$ display
- KPa/Psi/Bar display
- Battery voltage V
- Running Hour
- Starting timer:(999999)



Standard Protection Function

Genset Protection

- Programmable I/O signal
- Emergency stop

Engine Protection

- Stop for over speed
- Low oil pressure
- High Coolant temperature
- Sensor fail
- Alarm for low/high battery voltage
- Low battery voltage
- Fail to start/Cranking fail

Alternator Protection

- Over Voltage
- Over current
- Voltage signal lost
- Over Voltage
- Over frequency
- Under frequency

Control System Components

- Manual/auto/stop/start
- Setting button
- Fault status indicators
- Screen menu selection button
- Emergency stop button
- Digital displayer



Communication Interface (Option)

- International standard MODBUS communication protocol RS232/ RS485 is suitable for remote control and monitor; It is easy integrated with SCADA;.

Genset

Model	PYC35A
Prime Rating (kw)	24
Standby Rating (kw)	26
Rate current(A)	43
Power factor	0.8
Frequency(Hz)	50

Engine

Engine Model	YCDV254FHZ-40
Gross Engine output-Prime (kw)	30
Gross Engine output-Standby (kw)	33
Bore * stroke (mm)	89*100
Cylinders and structure	4 In line
Displacement(Liter)	2.5
Compression Ratio	17.5:1
Intake way	Turbocharged & Intercooled
Max intake resistance (KPa)	5
Air intake (m3/h)	70
Max exhaust back pressure (KPa)	10
Exhaust gas flow (m3/h)	73
Exhaust temp (°C)	620
Cooling way	Water Radiator & Fan
Fan exhaust flow (m3/min)	98.4
Coolant capacity (L)	10.2
Highest water temperature(°C)	95
Minimum air opening to room (m2)	0.7/0.6
Thermostat range (°C)	71-95
Max oil temperature (°C)	125
Lubrication system oil capacity (L)	6.5
Rate load fuel consumption(L/H)	7.9
Standard Governor/Class	Electronically controlled high voltage common rail
Emission	China Tier 3

Alternator

Rated Voltage(V)	230/400
Output Way	3 Phases, 4 wires
Rated power factor	0.8
Exciter	Brushless, Self-exciter
Max voltage regulation	±1%
Phase	3
Protection class	IP21-23
Insulation class	H

Controller

Brand	POWERTEC
-------	----------

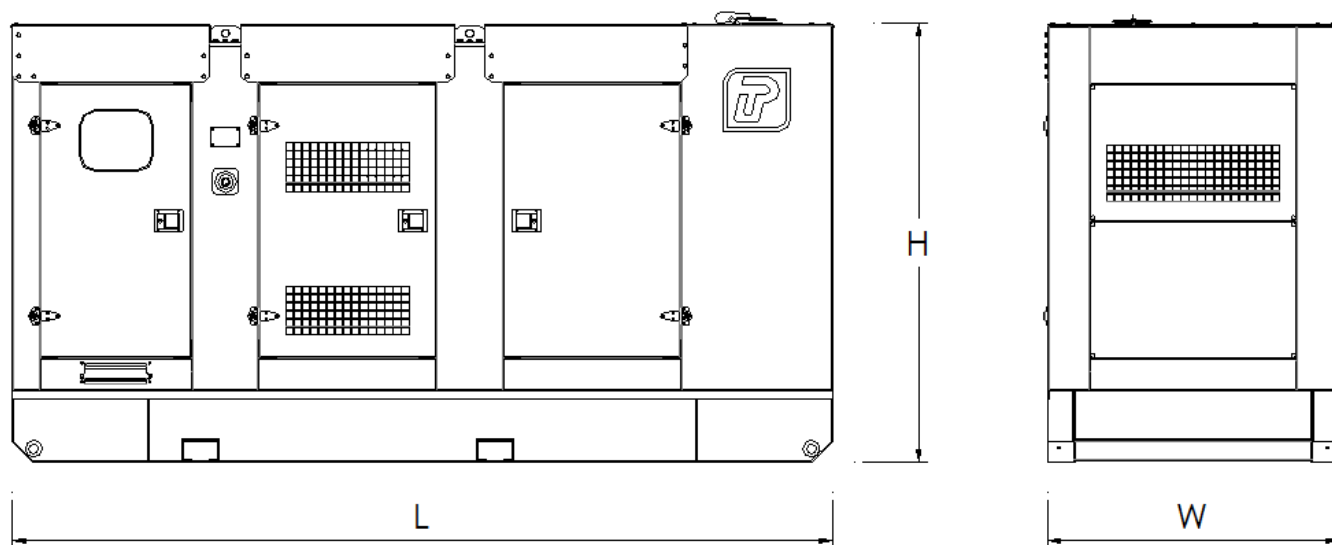

Type	Dimension (mm) (L*W*H)	Weight (kg)	Fuel Tank Capacity (L)
Open Type	1900*800*1200	750	110
Silent Type	2300*900*1550	1300	160

Contact Us

Powertec Generator System Inc.

Add: Danshui Yanna Industry Zone, Huiyang, Huizhou, Guangdong, China
Tel: +86 752-3911119 / 3911118
Fax: +86 752-3911110
Web: www.powertec.com.cn
Email: powertec@powertec.com.cn